

R2 Controller Installation Instructions

Float Switch Configuration

Pump-Up Mode

In a pump-up mode, the R2 relay will initiate by switching the pump when the fluid level in the tank falls below the lower tank level switch point. The R2 relay will remain energized (latched) and the pump will continue to operate until fluid fills the tank up to the high level switch point. When the fluid reaches the high level switch point, the control relay will de-energize and shut off the pump. The R2 relay will remain de-energized until the fluid falls below the tank's low level switch point.

Pump-Down Mode

In a pump-down mode, the R2 relay will initiate by switching on the pump when the fluid level in the tank reaches the upper tank level switch point. The R2 relay will remain energized (latched) and the pump will continue to operate until fluid in the tank empties down to the low level switch point. When the fluid falls below the low level switch point the R2 relay will de-energize and shut off the pump. The R2 relay will remain de-energized until the fluid reaches the tank's high level switch point.

Pump-Up

- Set both float switches “Normally Closed”.
- Connect Upper float switch to pins 5 and 6, Lower float switch to pins 5 and 8.
- Jumper supply voltage from terminal 2 to terminal 1.
- Connect one end of the pump / valve to terminal 3 and other end to terminal 7.
- Connect input power to terminals 2 and 7.

Pump-Down

- Set both float switches “Normally Open”.
- Connect Upper float switch to pins 5 and 8, Lower float switch to pins 5 and 6.
- Jumper supply voltage from terminal 2 to terminal 1.
- Connect one end of the pump / valve to terminal 3 and other end to terminal 7.
- Connect input power to terminals 2 and 7.

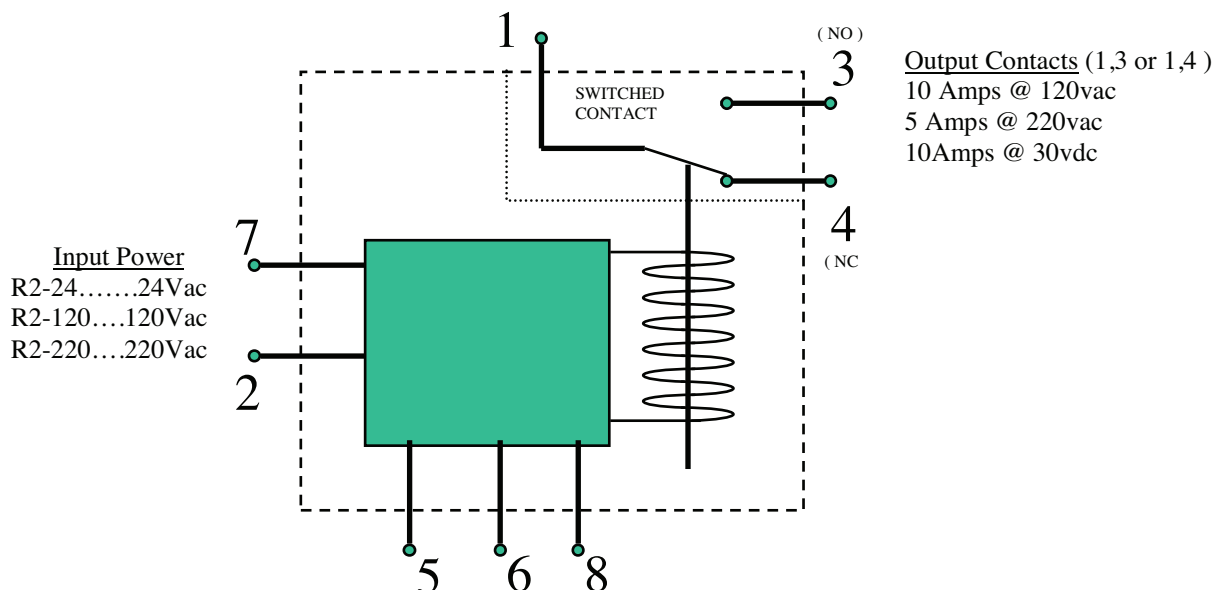



Sensor solutions for today and the future™

R2 Controller

Installation Instructions

Conductivity Sensor Configuration

- Input power is connected between pins 2 and 7
- Wire the “Common Probe” to pin 5
- Wire the “Lower Probe” to pin 6
- Wire the “Upper Probe” to pin 8

Pins 1-3 and 1-4 are isolated switched contacts to switch power to a valve or pump

